



# ED-VAN VANTİLATÖR SANAYİ ve TİCARET LTD. ŞTİ.

Merkez : TEMSİL PLAZA 1201/1 Sok. No:4/4F Yenişehir-İZMİR

Tel : (232) 433 78 33 Fax : (232) 433 78 28

Fabrika : Çıkrıkçı köyü EDREMIT

Tel : (266) 373 18 25 Fax : (266) 373 16 99

http://www.edvan.com.tr

E-Posta : info@edvan.com.tr



## H TİPİ STANDART DİREKT AKUPLE KÖRÜKLERİ



Kasım 2004

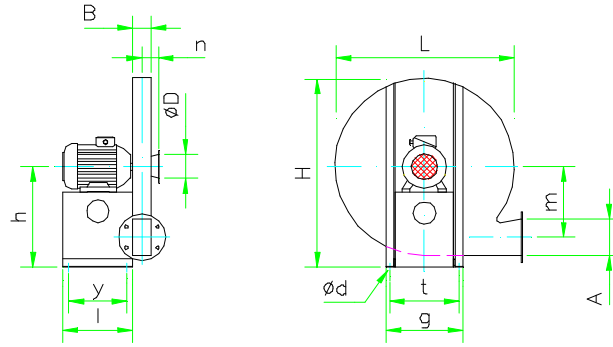

TİP	A	B	ø D	m	n	l	y	g	t	ød	h	H	L
H0	72	62	100	227	69	230	180	280	240	10	330	619	578
H1	93	68	125	216	72	250	200	280	240	10	330	619	578
H2	93	68	125	245	72	250	200	280	240	10	360	678	636
H2,5	120	75	150	264	76	300	250	300	260	10	395	745	700
H3	120	75	150	299	76	350	300	340	300	10	430	815	770
H3,5	120	75	150	338	76	350	295	370	320	12	495	918	845
H4	130	92	175	333	84	400	345	400	350	12	495	918	845
H5	130	92	175	376	84	400	345	400	350	12	545	1012	934
H5,5	120	75	150	428	76	400	345	400	350	12	590	1106	1032
H6	130	92	175	423	84	580	525	450	400	12	590	1106	1032

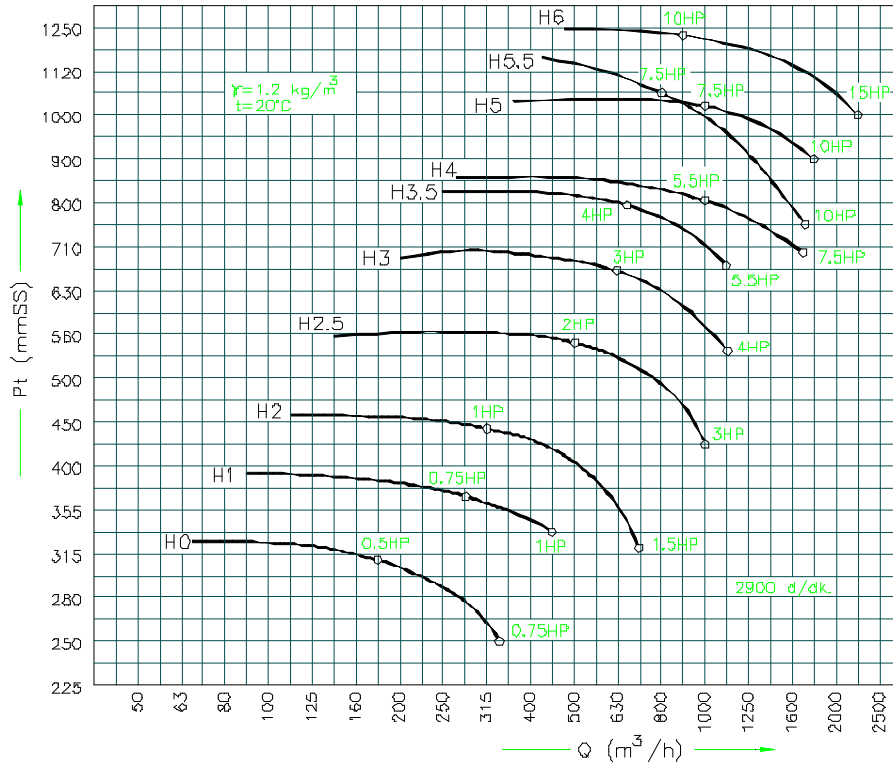

NOT: ÖLÇÜ DEĞİŞİKLİĞİ HAKKIMIZ MAHFUZDUR. BU EĞRİLER ±%5 TOLERANSLIDIR.